



AI KITCHEN
Scale: NTS



KITCHEN **AI**
Scale: NTS

DESIGNED BY
SHAI ZEEV
ABN: 47 640 715 279
6b Larman St, Bentleigh East 3165
Mob: 0407004576
E-mail: sales@thecabinetmerchant.com.au

PROJECT TITLE
HOME JOINERIES

CLIENT ADDRESS

CLIENT NAME



AI KITCHEN
Scale: NTS



SHELVES **AI**
Scale: NTS

DESIGNED BY
SHAI ZEEV
ABN: 47 640 715 279
6b Larman St, Bentleigh East 3165
Mob: 0407004576
E-mail: sales@thecabinetmerchant.com.au

PROJECT TITLE
HOME JOINERIES

CLIENT ADDRESS

CLIENT NAME



AI KITCHEN
Scale: NTS



COFFEE AREA **AI**
Scale: NTS

DESIGNED BY
SHAI ZEEV
ABN: 47 640 715 279
6b Larman St, Bentleigh East 3165
Mob: 0407004576
E-mail: sales@thecabinetmerchant.com.au

PROJECT TITLE
**HOME
JOINERIES**

CLIENT ADDRESS

CLIENT NAME



AI PANTRY
Scale: NTS



FAMILY AREA **AI**
Scale: NTS

DESIGNED BY
SHAI ZEEV
ABN: 47 640 715 279
6b Larman St, Bentleigh East 3165
Mob: 0407004576
E-mail: sales@thecabinetmerchant.com.au

PROJECT TITLE
HOME JOINERIES

CLIENT ADDRESS

CLIENT NAME



AI POWDER ROOM
Scale: NTS

CLIENT NAME

CLIENT ADDRESS

PROJECT TITLE
HOME
JOINERIES

DESIGNED BY
SHAI ZEEV

ABN: 47 640 715 279
6b Larman St, Bentleigh East 3165
Mob: 0407004576
E-mail: sales@thecabinetmerchant.com.au

*****NOTE: OVERHANG DOORS TO HANG DOWN 20mm FOR FINGERPULL**

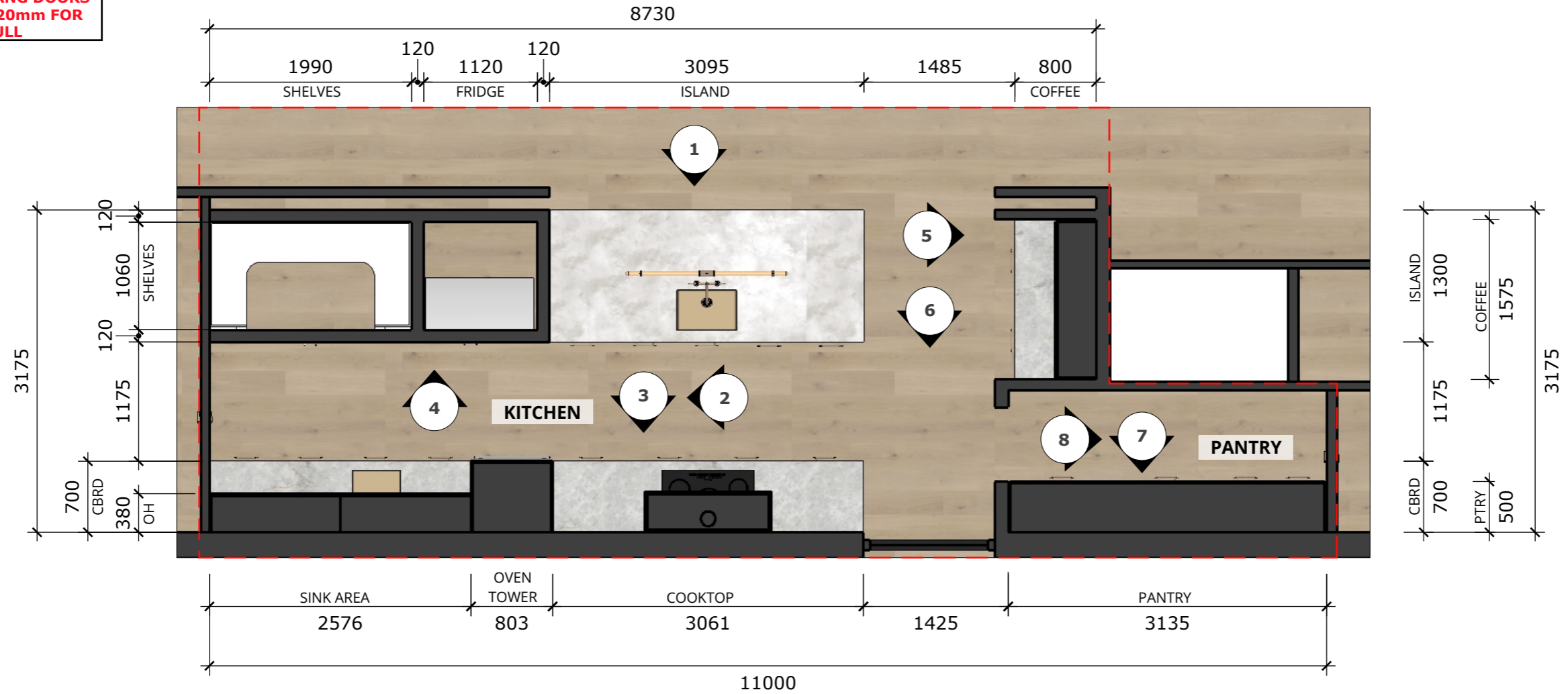

A :: KITCHEN PLAN
001 scale: 1=50mm

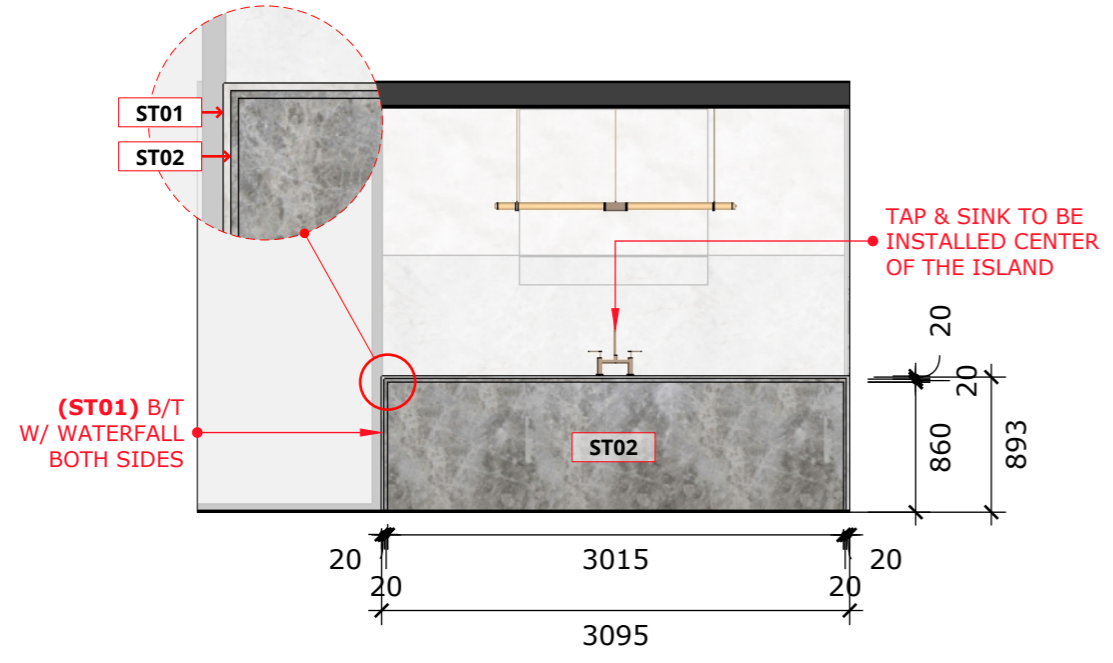

A :: KITCHEN ELEVATION 1
002 scale: 1=50mm

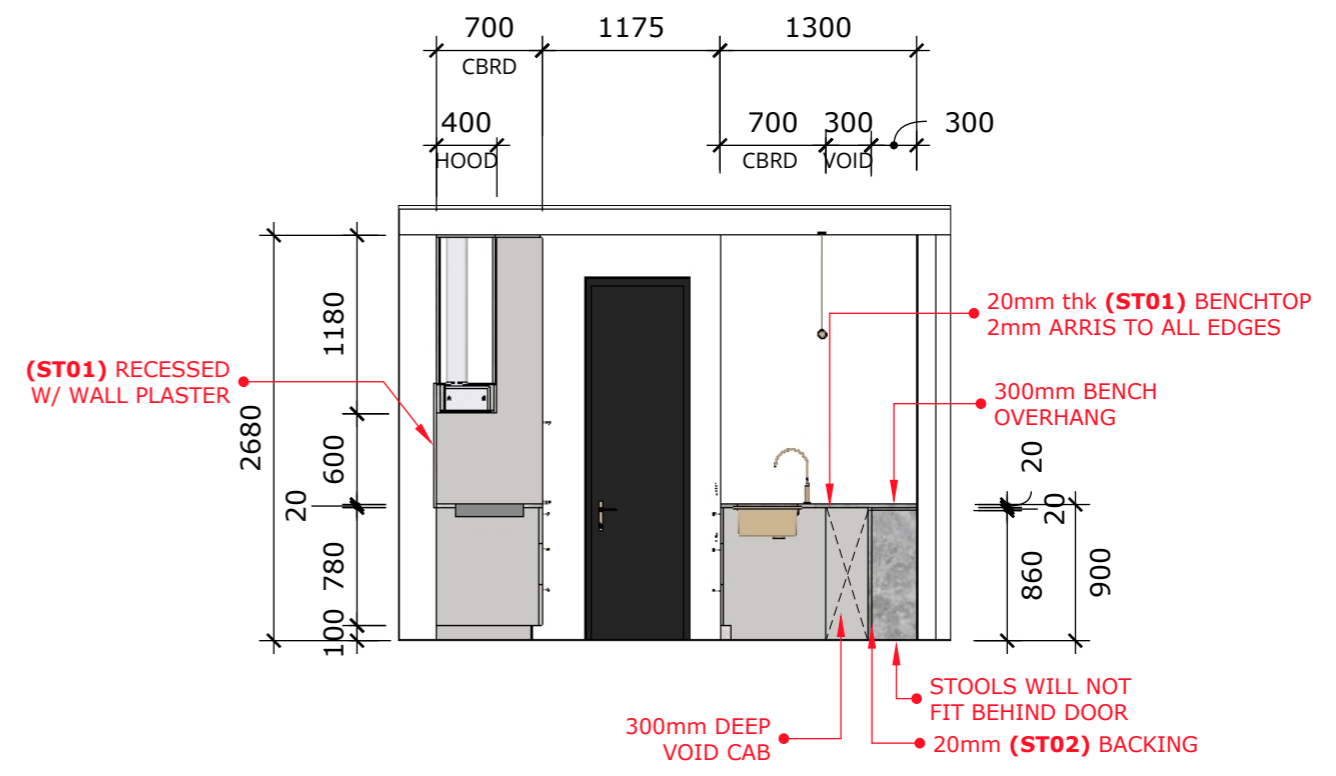

A :: KITCHEN ELEVATION 2
003 scale: 1=50mm

FINISHES LEGEND

ST01 - LIGHT GREY STONE	JN01 - VENEER WITH 2 PAC PAINT FINISH	JN03 - 2 PAC PAINT FINISH TO EX. JOINERY	WL01 - VENETIAN PLASTER
ST02 - DARK GREY STONE	JN02 - WHITE MELAMINE (CAB. INTERIOR)	JN04 - 2 PAC PAINT FINISH	WL02 - PAINTED PLASTERBOARD

6

au

DESIGNED BY
SHAI ZEEV

PROJECT TITLE
HOME JOINERIES

CLIENT ADDRESS

CLIENT NAME

ABN: 47 640 715 279
6b Larman St, Bentleigh East 3165
Mob: 0407004576
E-mail: sales@thecabinetmerchant.com.au

THE CABINET MERCHANT

*****NOTE: OVERHANG DOORS TO HANG DOWN 20mm FOR FINGERPULL**

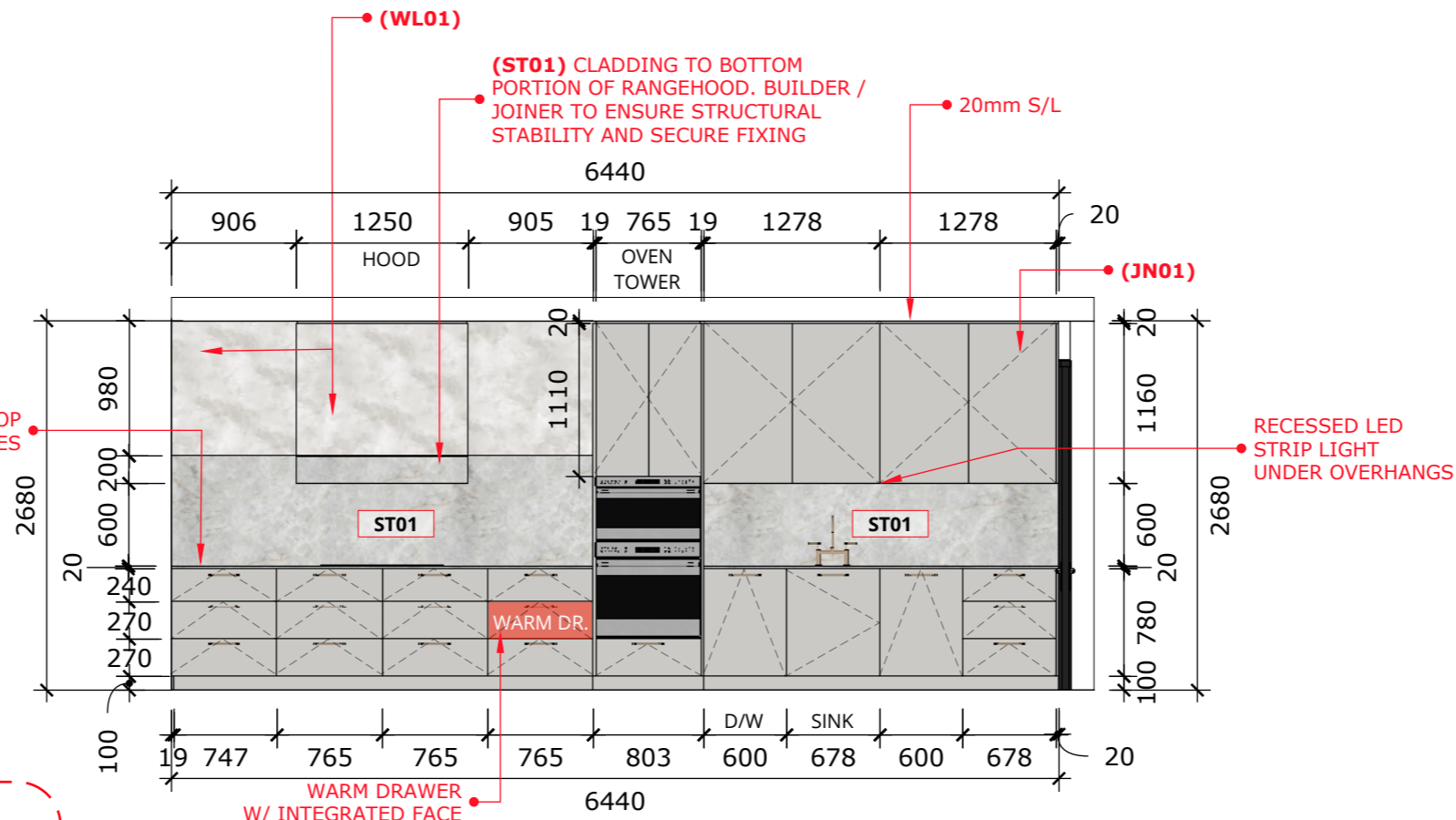

A :: KITCHEN ELEVATION 3
 001 scale: 1=50mm

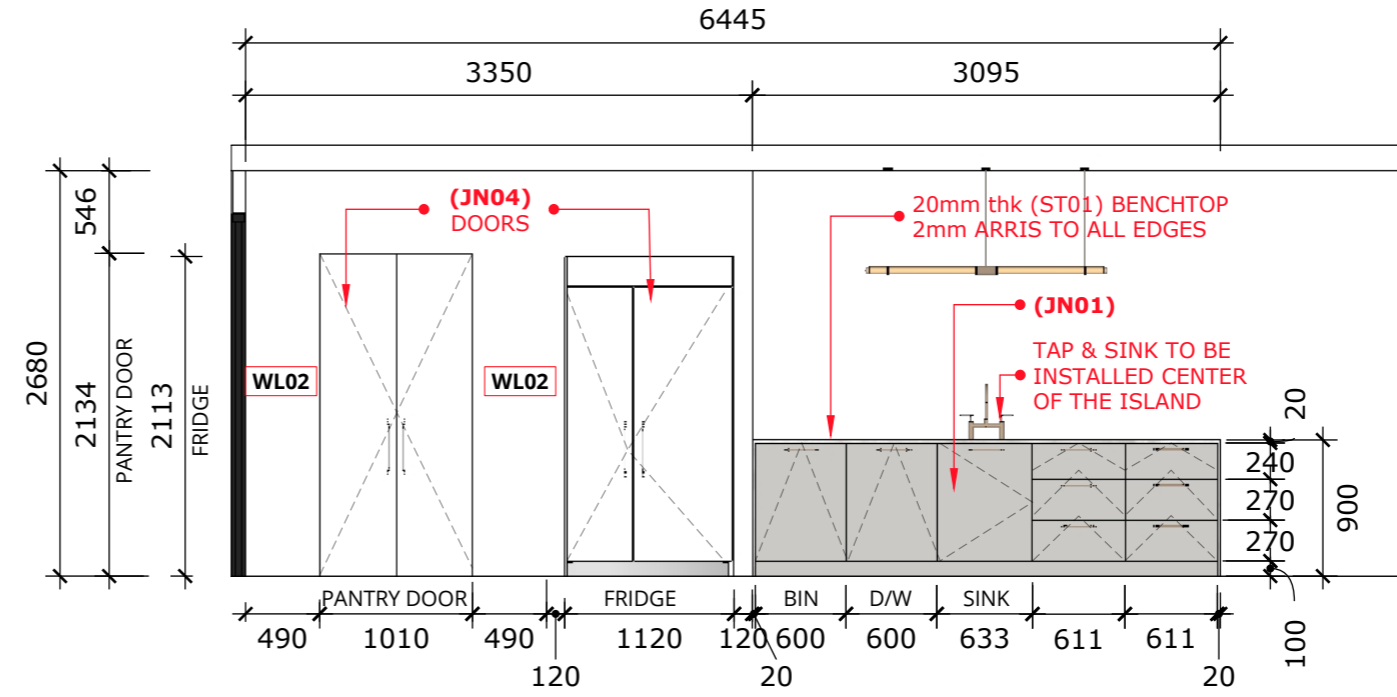
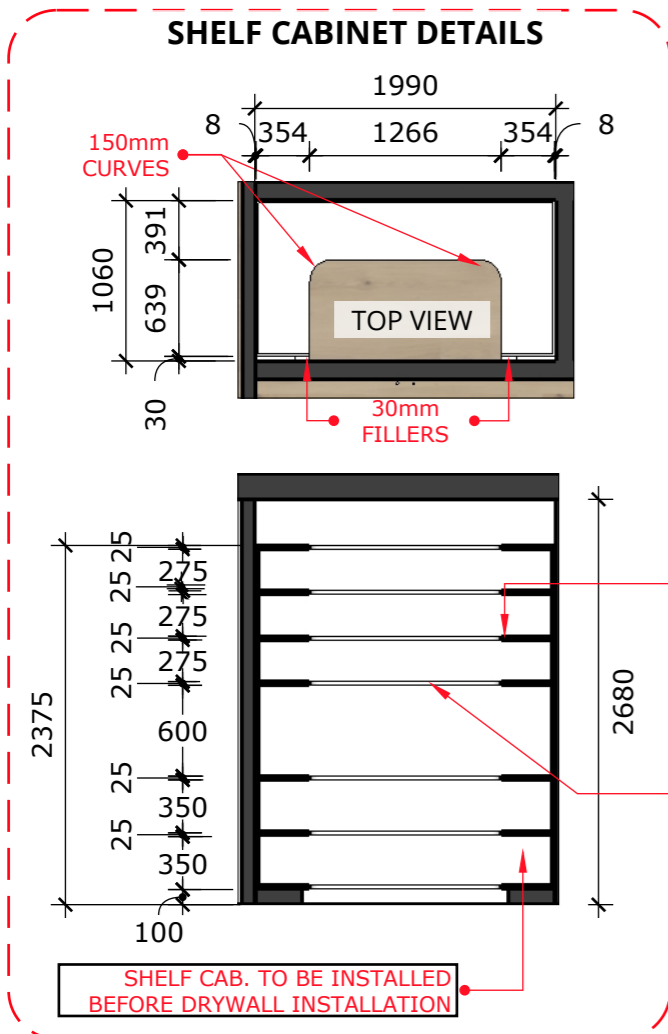

A :: KITCHEN ELEVATION 4
 002 scale: 1=50mm

NOTE:
 FRIDGE - SUB ZERO
 ICBCL4250S/O

FINISHES LEGEND

ST01 - LIGHT GREY STONE	JN01 - VENEER WITH 2 PAC PAINT FINISH	JN03 - 2 PAC PAINT FINISH TO EX. JOINERY	WL01 - VENETIAN PLASTER
ST02 - DARK GREY STONE	JN02 - WHITE MELAMINE (CAB. INTERIOR)	JN04 - 2 PAC PAINT FINISH	WL02 - PAINTED PLASTERBOARD

DESIGNED BY
SHAI ZEEV
 ABN: 47 640 715 279
 6b Larman St, Bentleigh East 3165
 Mob: 0407004576
 E-mail: sales@thecabinetmerchant.com.au

PROJECT TITLE
HOME JOINERIES

CLIENT ADDRESS

CLIENT NAME

***NOTE: OVERHANG DOORS TO HANG DOWN 20mm FOR FINGERPULL

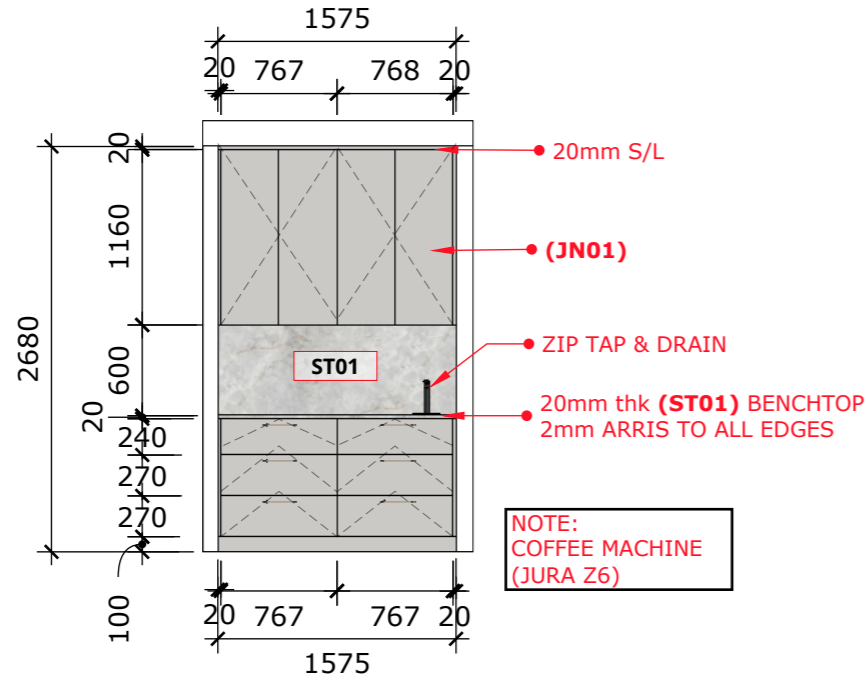

A :: KITCHEN ELEVATION 5
001 scale: 1=50mm

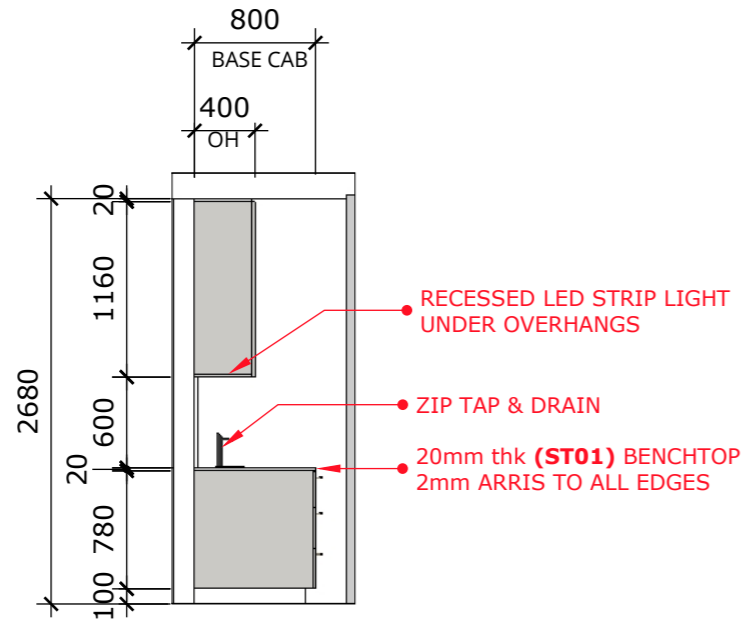

A :: KITCHEN ELEVATION 6
002 scale: 1=50mm

***NOTE: OVERHANG DOORS TO HANG DOWN 20mm FOR FINGERPULL

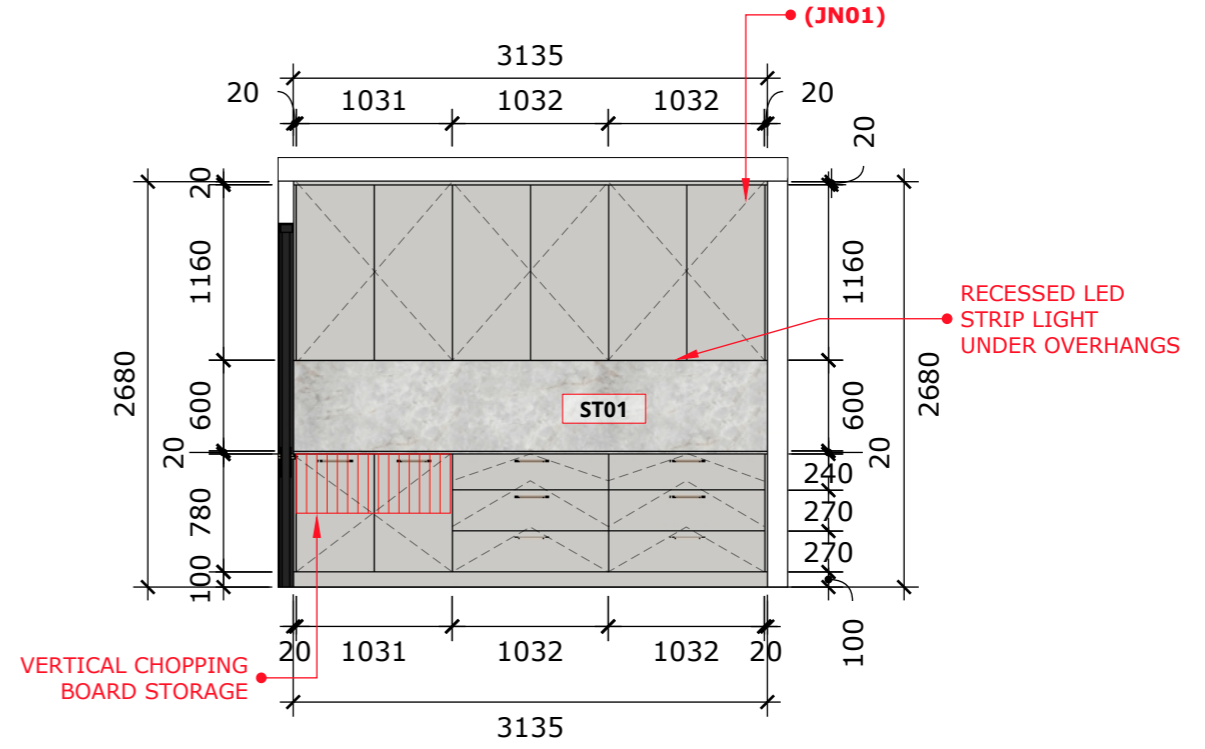

A :: KITCHEN ELEVATION 7
003 scale: 1=50mm

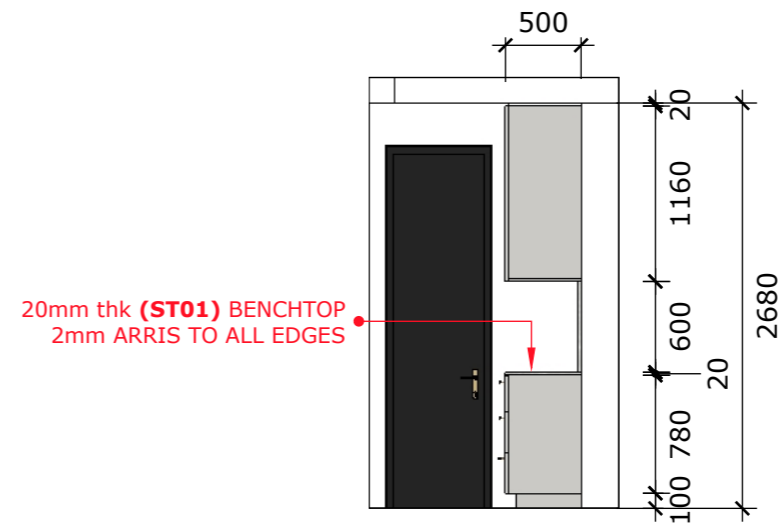

A :: KITCHEN ELEVATION 8
004 scale: 1=50mm

FINISHES LEGEND

ST01 - LIGHT GREY STONE	JN01 - VENEER WITH 2 PAC PAINT FINISH	JN03 - 2 PAC PAINT FINISH TO EX. JOINERY	WL01 - VENETIAN PLASTER
ST02 - DARK GREY STONE	JN02 - WHITE MELAMINE (CAB. INTERIOR)	JN04 - 2 PAC PAINT FINISH	WL02 - PAINTED PLASTERBOARD

DESIGNED BY
SHAI ZEEV
 ABN: 47 640 715 279
 6b Larman St, Bentleigh East 3165
 Mob: 0407004576
 E-mail: sales@thecabinetmerchant.com.au

PROJECT TITLE
HOME
JOINERIES

CLIENT ADDRESS

CLIENT NAME

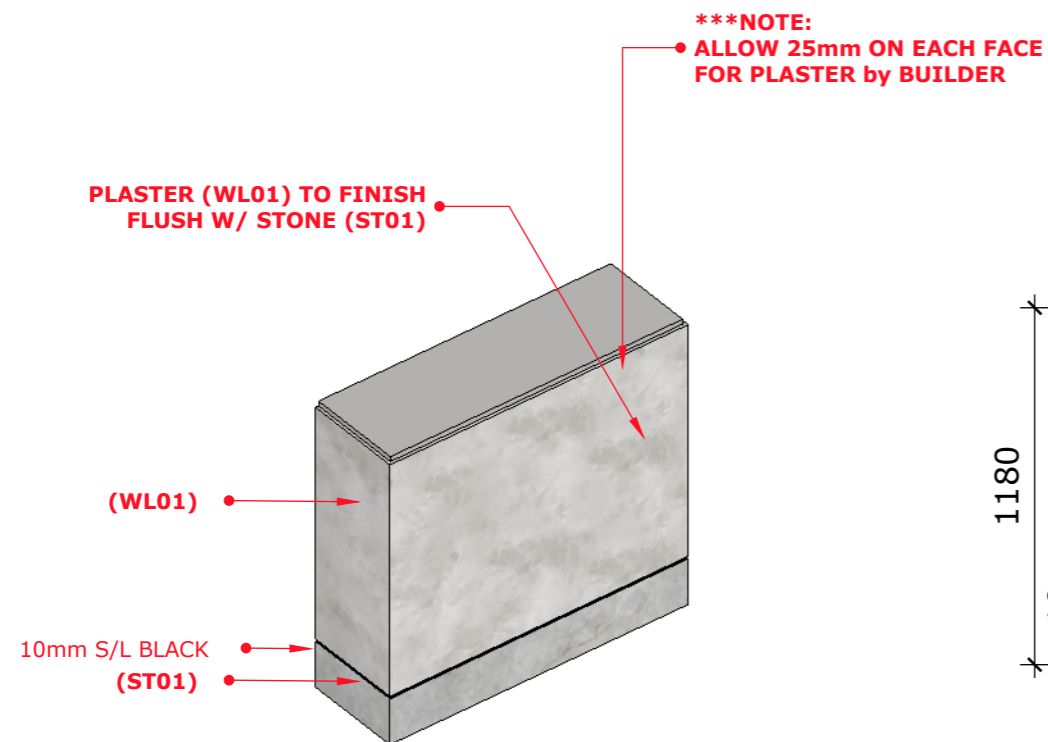

A :: RANGEHOOD ISO VIEW
001 scale: 1=25mm

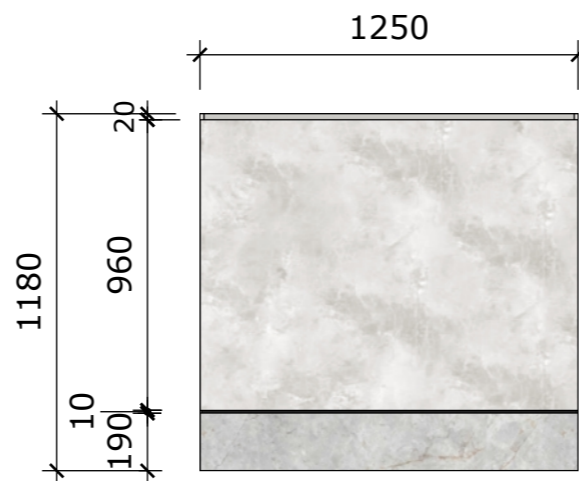

A :: RANGEHOOD FRONT ELEV.
002 scale: 1=25mm

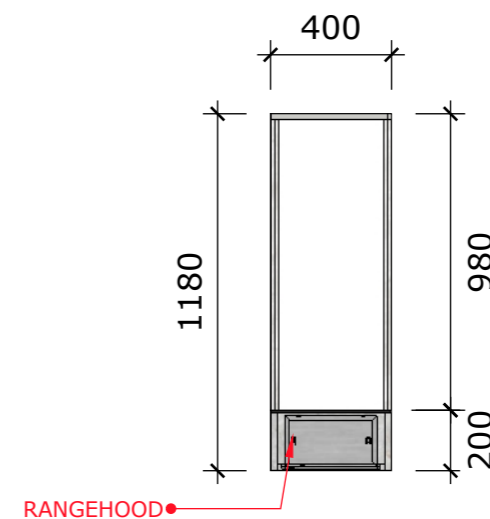

A :: RANGEHOOD SECTION
003 scale: 1=25mm

FINISHES LEGEND

ST01 - LIGHT GREY STONE	JN01 - VENEER WITH 2 PAC PAINT FINISH	JN03 - 2 PAC PAINT FINISH TO EX. JOINERY	WL01 - VENETIAN PLASTER
ST02 - DARK GREY STONE	JN02 - WHITE MELAMINE (CAB. INTERIOR)	JN04 - 2 PAC PAINT FINISH	WL02 - PAINTED PLASTERBOARD

Flush Inset Panels

The flush inset application is an overlay model with flush inset panels. It is not a separate model.

The flush inset design allows custom panels to be installed flush with adjacent cabinets. Flush inset panels are typically created by combining a 19 mm custom panel, a 3 mm spacer panel, and a 6 mm backer panel. Refer to the illustration below.

For flush inset panels thicker than 19 mm, a 90° door stop may be required to prevent interference with adjacent cabinets. Refer to the full-scale templates at the end of this guide.

PANEL OFFSET

The illustrations on the right provide panel offsets and reveals for Classic series models in a flush inset application. Refer to the chart below for reference to the illustrations.

PANEL OFFSET

SIDE-BY-SIDE	ILLUS
Doors (hinge) / Grille Sides	A
Doors (handle) Sides	B
Grille Top	C
Grille Bottom / Door Top	D
Door Bottom	E

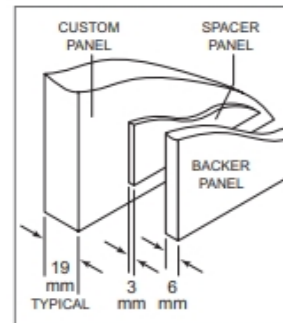

Panel assembly (rear view)

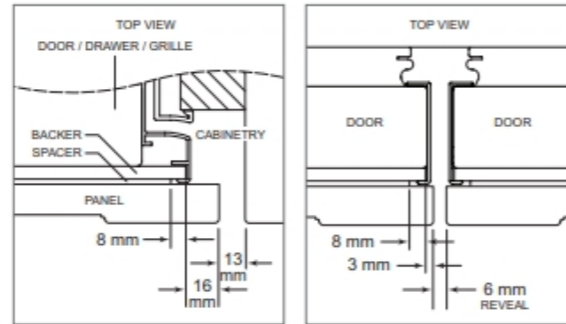

Illus. A

Illus. B

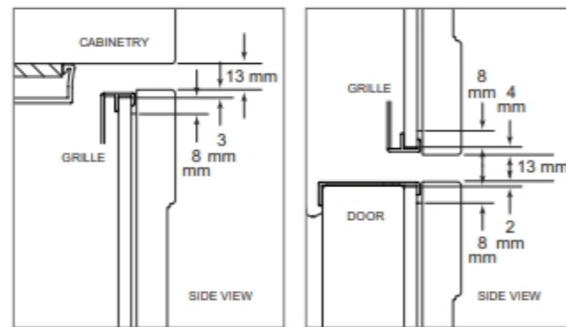

Illus. C

Illus. D

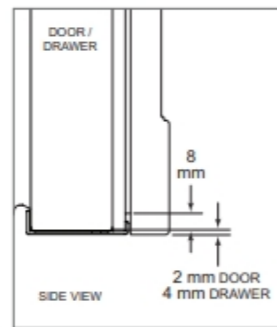

Illus. E

Classic Series Refrigeration

Opening Dimensions

FLUSH INSET INSTALLATION

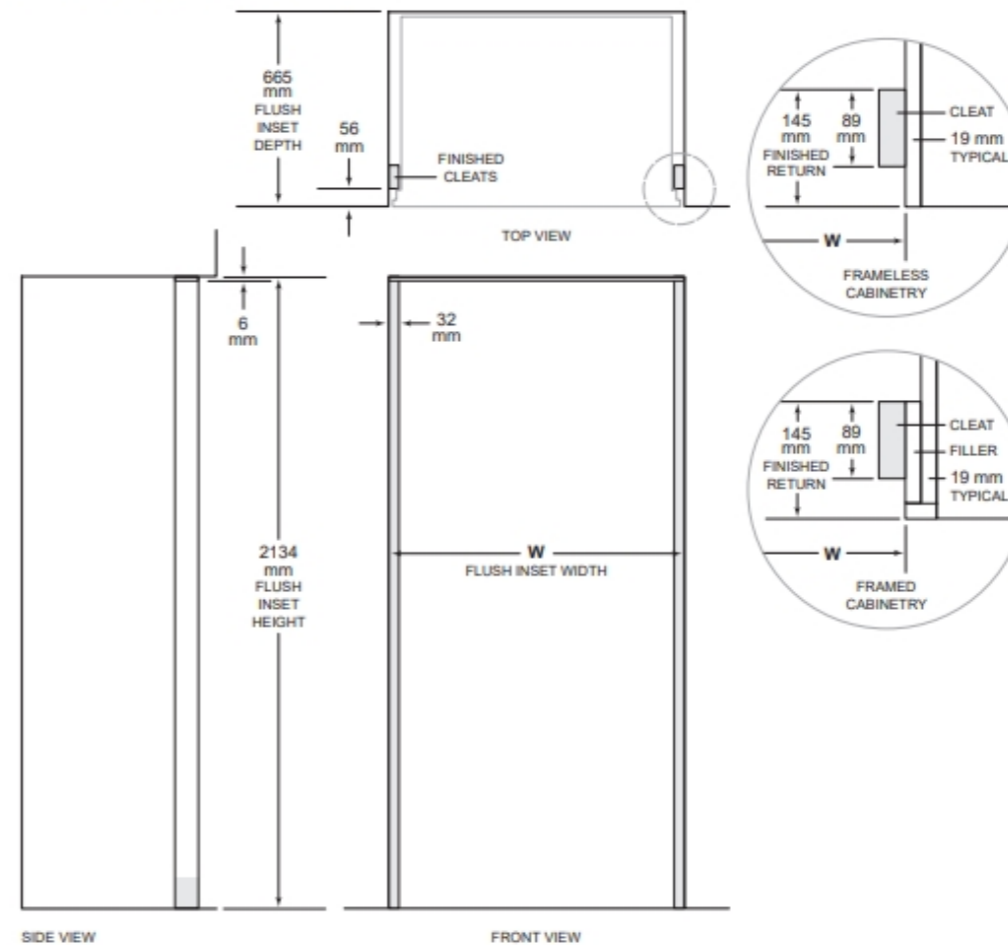

SIDE VIEW

FRONT VIEW

NOTE: 89 mm finished returns and shaded areas will be visible and should be finished to match cabinetry. Shaded line represents profile of unit with 19 mm panel.

FLUSH INSET WIDTH	W
1067 mm Model	1118 mm
1219 mm Model	1270 mm

Flush inset is available for overlay models only. Dimensions assume a 19 mm panel thickness.

DESIGNED BY
SHAI ZEEV
ABN: 47 640 715 279
6b Larman St, Bentleigh East 3165
Mob: 0407004576
E-mail: sales@thecabinetmerchant.com.au

PROJECT TITLE
HOME
JOINERIES

CLIENT ADDRESS

CLIENT NAME

Classic Series Refrigeration

Flush Inset Panel Dimensions

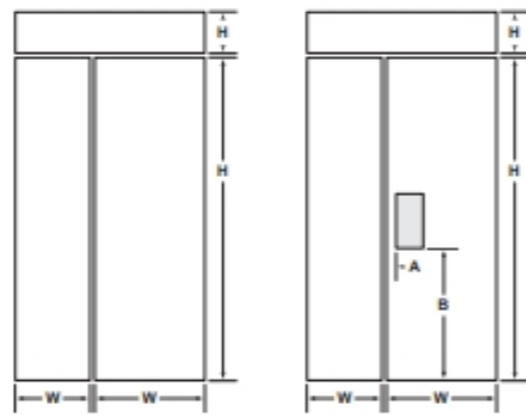

ICBCL4250S(ID)
ICBCL4850S(ID)

ICBCL4850SD

MODEL ICBCL4250S(ID)

REFRIGERATOR	W	H
Flush Inset Panel	649 mm	1810 mm
Spacer Panel	614 mm	1789 mm
Backer Panel	630 mm	1805 mm

FREEZER	W	H
Flush Inset Panel	437 mm	1810 mm
Spacer Panel	402 mm	1789 mm
Backer Panel	418 mm	1805 mm

GRILLE	W	H
Flush Inset Panel	1092 mm	197 mm
Spacer Panel	1045 mm	173 mm
Backer Panel	1060 mm	189 mm

MODEL ICBCL4850S(ID), ICBCL4850SD

REFRIGERATOR	W	H
Flush Inset Panel	743 mm	1810 mm
Spacer Panel	708 mm	1789 mm
Backer Panel	724 mm	1805 mm

FREEZER	W	H
Flush Inset Panel	495 mm	1810 mm
Spacer Panel	460 mm	1789 mm
Backer Panel	476 mm	1805 mm

GRILLE	W	H
Flush Inset Panel	1245 mm	197 mm
Spacer Panel	1197 mm	173 mm
Backer Panel	1213 mm	189 mm

ICBCL4850SD	W	H
Dispenser Cutout	162 mm	330 mm
Cutout Location	A 54 mm	B 832 mm

DESIGNED BY
SHAI ZEEV
ABN: 47 640 715 279
6b Larman St, Bentleigh East 3165
Mob: 0407004576
E-mail: sales@thecabinetmerchant.com.au

PROJECT TITLE
HOME
JOINERIES

CLIENT ADDRESS

CLIENT NAME

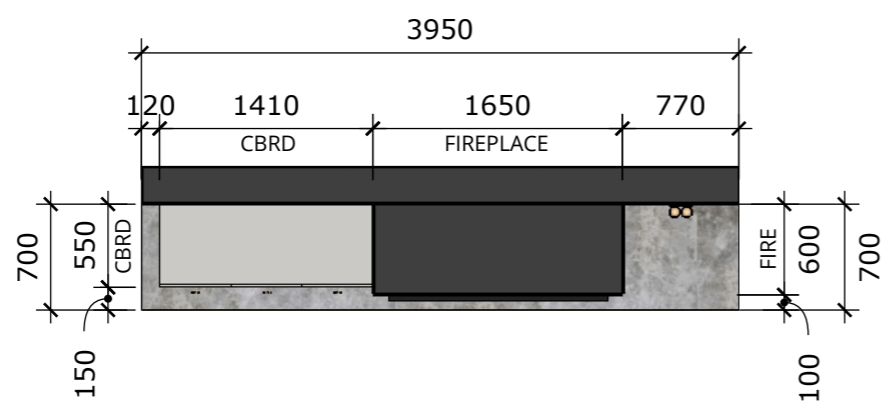

A :: FAMILY AREA PLAN
001 scale: 1=50mm

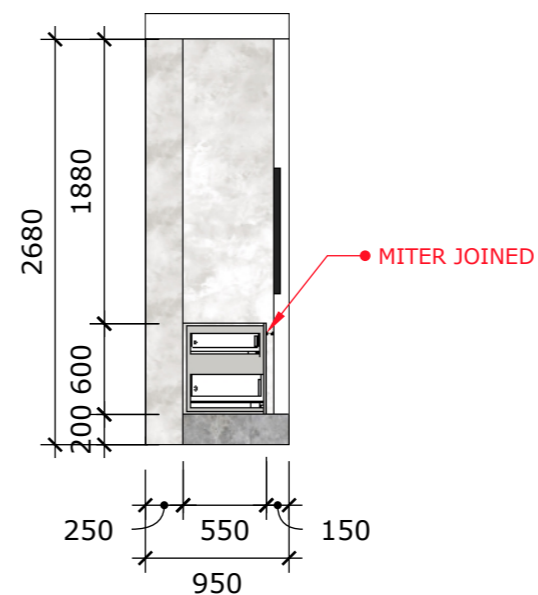

A :: FAMILY AREA SECTION
002 scale: 1=50mm

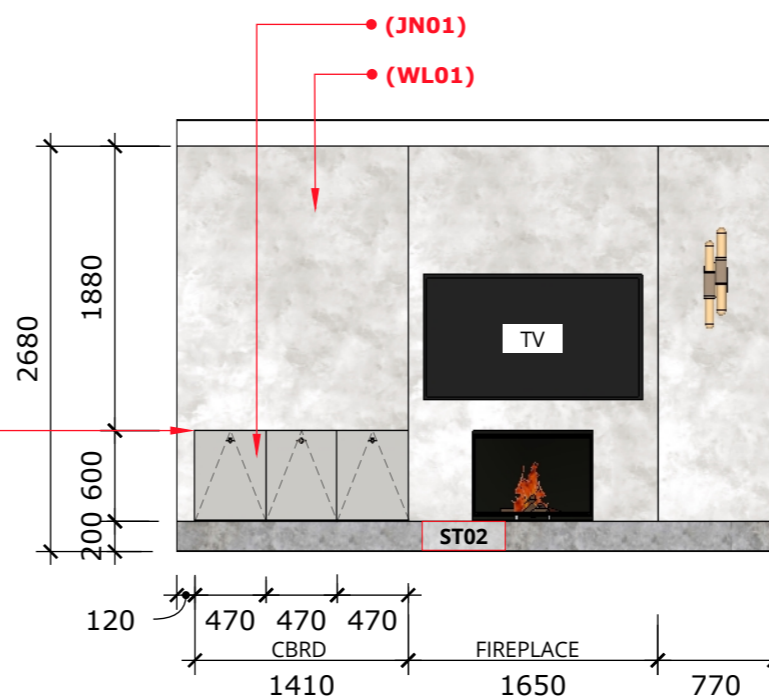
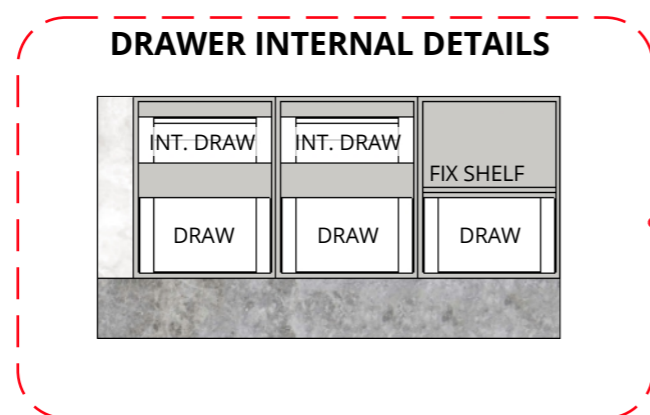

A :: FAMILY AREA FRONT ELEV.
003 scale: 1=50mm

DESIGNED BY
SHAI ZEEV
ABN: 47 640 715 279
6b Larman St, Bentleigh East 3165
Mob: 0407004576
E-mail: sales@thecabinetmerchant.com.au

PROJECT TITLE
HOME
JOINERIES

CLIENT ADDRESS

CLIENT NAME

FINISHES LEGEND

ST01 - LIGHT GREY STONE
ST02 - DARK GREY STONE

JN01 - VENEER WITH 2 PAC PAINT FINISH
JN02 - WHITE MELAMINE (CAB. INTERIOR)

JN03 - 2 PAC PAINT FINISH TO EX. JOINERY
JN04 - 2 PAC PAINT FINISH

WL01 - VENETIAN PLASTER
WL02 - PAINTED PLASTERBOARD

DESIGNED BY
SHAI ZEEV
ABN: 47 640 715 279
6b Larman St, Bentleigh East 3165
Mob: 0407004576
E-mail: sales@thecabinetmerchant.com.au

PROJECT TITLE
HOME
JOINERIES

CLIENT ADDRESS

CLIENT NAME

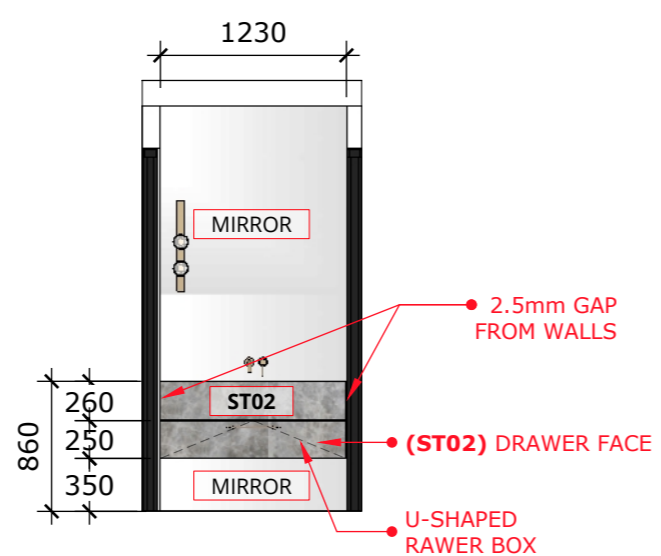

A :: VANITY FRONT ELEV
001 scale: 1=50mm

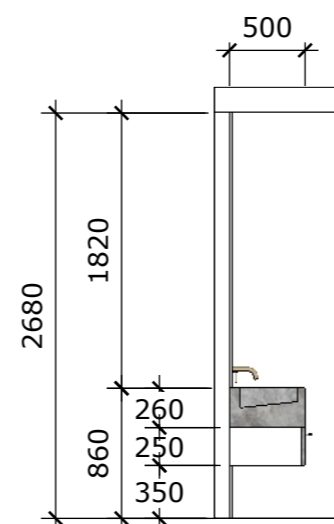

A :: VANITY SECTION
002 scale: 1=50mm

FINISHES LEGEND

ST01 - LIGHT GREY STONE	JN01 - VENEER WITH 2 PAC PAINT FINISH	JN03 - 2 PAC PAINT FINISH TO EX. JOINERY	WL01 - VENETIAN PLASTER
ST02 - DARK GREY STONE	JN02 - WHITE MELAMINE (CAB. INTERIOR)	JN04 - 2 PAC PAINT FINISH	WL02 - PAINTED PLASTERBOARD